

4

3

2

1

SPECIFICATIONS

ELECTRICAL
FREQUENCY RANGE _____ DC TO 18 GHz

ATTENUATION
0-6 dB _____ ±0.3 dB
7-10, 20 dB _____ ±0.5 dB
11-19, 21-30 dB _____ ±0.75 dB
40 dB _____ ±1.0 dB
50, 60 dB _____ ±2.0 dB
(AVAILABLE IN 1/2 dB VALUES 0.5 - 10.5 dB)

VSWR
DC-4 _____ 1.15:1 MAX
4-12.4 _____ 1.25:1 MAX
12.4-18 _____ 1.35:1 MAX

POWER (AVG) _____ 2 WATTS 0.5 dB AND ABOVE
50 WATTS FOR 0 dB UNIT
DERATED LINEARLY FROM 100% @+25°C TO 10% @ +125°C

POWER (PEAK) _____ 500 WATTS
5 μs PULSE W, 0.05% DUTY CYCLE

IMPEDANCE _____ 50 OHMS

MECHANICAL
OPERATING TEMP RANGE _____ -65 TO +125°C
1.24 LENGTH / WEIGHT MAX _____ 0.40oz. (11.3g)
1.80 LENGTH / WEIGHT MAX _____ 0.60oz. (15.3g)

MATERIAL
OUTER CONDUCTOR _____ STAINLESS STEEL NON
MAGNETIC, PASSIVATED FINISH.
CENTER CONDUCTOR _____ BERYLLIUM COPPER, GOLD PLATED
FINISH.
DIELECTRIC _____ TEFLON.

MATERIALS & FINISHES TYPICALLY PER MIL-PRF-39012

MARKING
PART LOOKS LIKE PRODUCT IMAGE ABOVE.
PART MARKING ORIENTATION AND FORMAT AS SHOWN.
MARKING TO BE AS LARGE AS POSSIBLE, CLEAR, READABLE, AND A
BLACK COLOR.
REPLACE "X-XX" WITH PART NUMBER SPECIFIED ON WORK ORDER.

PLUG JACK	dB VALUE	PLUG JACK	dB VALUE
2082-6191-00	0.0	2082-6193-10	10.0
2082-6197-00	0.5	2082-6199-10	10.5
2082-6191-01	1.0	2082-6194-11	11.0
2082-6197-01	1.5	2082-6194-12	12.0
2082-6191-02	2.0	2082-6194-13	13.0
2082-6197-02	2.5	2082-6194-14	14.0
2082-6191-03	3.0	2082-6194-15	15.0
2082-6197-03	3.5	2082-6194-16	16.0
2082-6192-04	4.0	2082-6194-17	17.0
2082-6198-04	4.5	2082-6194-18	18.0
2082-6192-05	5.0	2082-6194-19	19.0
2082-6198-05	5.5	2082-6194-20	20.0
2082-6192-06	6.0	2082-6195-30	30.0
2082-6198-06	6.5	2082-6196-40	40.0
2082-6193-07	7.0	2082-6196-50	50.0
2082-6199-07	7.5	2082-6196-60	60.0
2082-6193-08	8.0		
2082-6199-08	8.5		
2082-6193-09	9.0		
2082-6199-09	9.5		

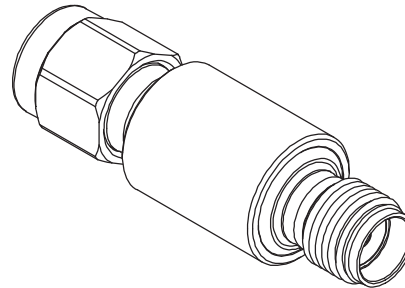

REVISIONS				
REV	DESCRIPTION	ECO #	DATE	APPROVED
H	ADDED TABLE	14-218	5/30/14	T.KUHN
J	ADDED DATE CODE	14-354	10/16/14	T.KUHN

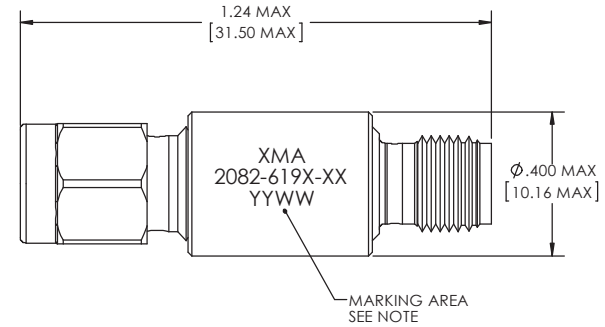

0 THRU 30 dB

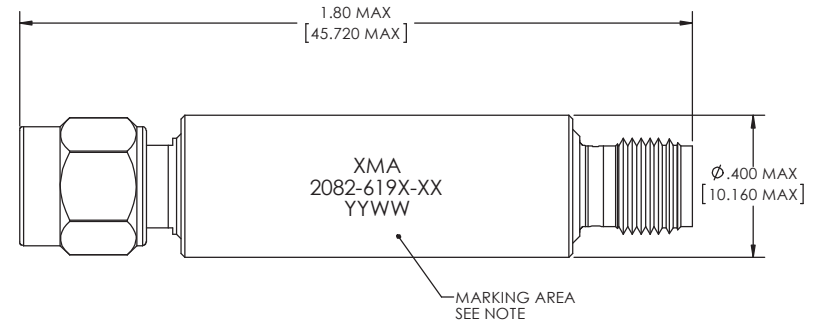

40, 50, & 60 dB

QTY.	PART NUMBER	DESCRIPTION	ITEM NO.
X	2082-619X-dB	ATTENUATOR, SMA-m/f, DC-18GHz, 2W	
1	TA-2082-619X-dBU	ASSY, ATTENUATOR, SMA-m/f, DC-18GHz, 2W, UNMARKED	1

DRAWING PRACTICES PER ANSI Y14.5
 DIMENSIONS ARE IN INCHES AND
 APPLY BEFORE/AFTER PROCESSING

SURFACE
 ROUGHNESS
 FINISHES
 SEE NOTES

MATERIAL:
 SEE NOTES

NOTE:
 THIS DRAWING INCORPORATES
 THIRD ANGLE PROJECTION.

INTERPRET LAW ANSI Y14.5-1982

UNLESS OTHERWISE SPECIFIED
 TOLERANCES IN:
 DECIMALS INCH (MM)

X" .05" [1.27]
 .XX" .03" [.76]
 .XXX" .010" [.25]

ANGLES ±0°30'
 REMOVE ALL BURRS/SHARP W/
 BREAK / R OF .003" TO .0005"
 UNLESS OTHERWISE NOTED
 DIAS CONCENTRIC <.003 T.I.F.

DO NOT SCALE PRINT

DRAWN DATE
 McCORMICK 5/15/14

CHECKED DATE
 McCORMICK 5/15/14

ENG APPR. DATE
 T.KUHN 5/15/14

THESE DRAWINGS AND
 SPECIFICATIONS ARE THE PROPERTY
 OF XMA CORP. OR OMNI SPECTRA
 AND SHALL NOT BE REPRODUCED,
 COPIED NOR USED IN WHOLE OR IN
 PART AS A BASIS FOR THE
 MANUFACTURE OR SALE OF OTHER
 ITEMS WITHOUT THE EXPRESS
 WRITTEN PERMISSION OF XMA CORP.

Phone: 603-222-2256 Fax: 603-222-2259
 150 Dow Street, Manchester, NH 03103

ATTENUATOR, SMA-m/f, DC-18GHz, 2W

SIZE	CAGE CODE	DRAWING NUMBER	REV
C	3HT76	2082-619X-dB	J

SCALE PLATED AREA 50 IN SHEET 1 OF 1

4

3

2

1