

CATALOG NUMBER

9001-823-0

MATERIAL AND FINISH

FRONT BODY, SLEEVE, CRES 303; PASSIVATED  
 PLUNGER AND CAP:

INSERT AND SLEEVE: 17-4 PH STAINLESS STEEL; PASSIVATED

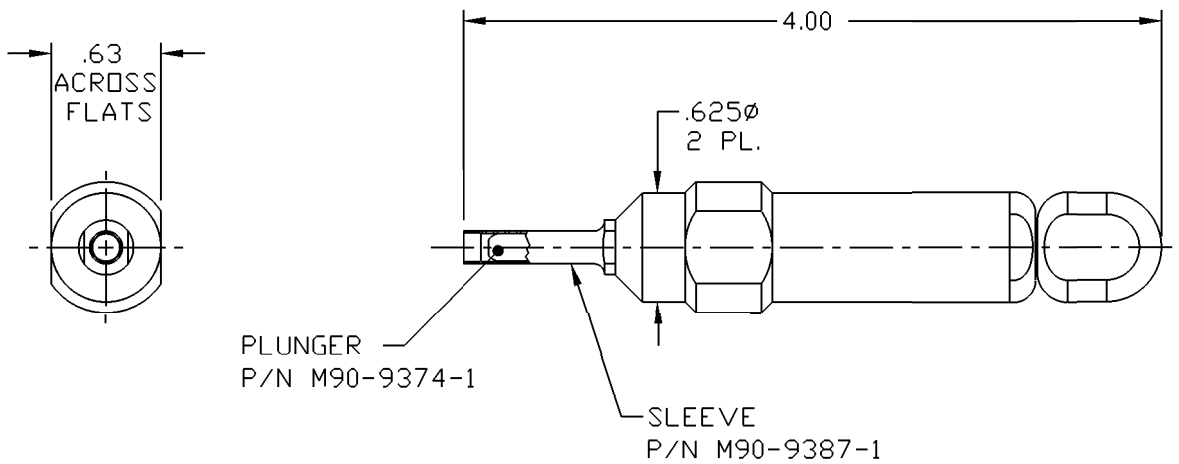
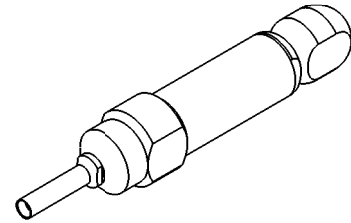

NOTES:

- FITS CONNECTORS: 0118-952-4-CM, 0118-928-3-CM, 0118-928-4-CM, 0118-842-3-TAB AND 0118-942-5-CM-FD.

This drawing and any data contained herein is the property of Corning Gilbert Inc., and constitutes and contains proprietary and confidential information. Neither receipt nor possession of this drawing confers or transfers any right to duplicate, use or disclose any information contained herein except as expressly authorized by Corning Gilbert Inc.

GPPD MALE  
 SNAP-IN  
 REMOVAL TOOL

IDENT CODE:  
 82316

REVISION: C

**Corning Gilbert Inc.**

SOURCE FILE: SK-2354

DWG. NO.: OL-9001-823-0

ASSY. PROC.: -