

DWG. NO.	REV.	
SYM.	REVISION	DATE
A	REL. ECO GM-3494	3/1/89
		DB

MATERIAL & FINISH

CRES 303 PER ASTM A484 &  
 ASTM A582 PASSIVATE PER  
 MIL-F-14072 E 300

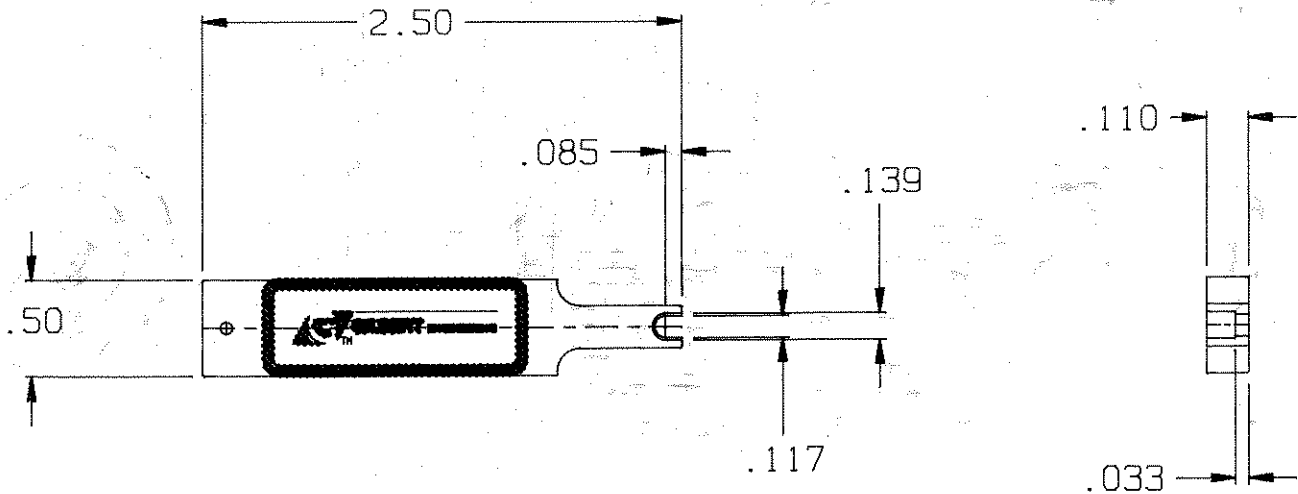

CODE IDENT NO.  
 82316

F-327		GILBERT ENGINEERING COMPANY	
BY	C LONG	DATE	2/17/89
CHECKED	<i>DB</i>	DATE	3-1-89
SHEET 1 OF 1		DWG. NO.	9001-944-3
		REV	A

TITLE OUTLINE DRAWING: INSTALLATION/  
 WITHDRAWAL TOOL

OL