



3 GHz N FAILSAFE TRANSFER SWITCH

OPTIONS:

R F CHARACTERISTICS

FREQUENCY RANGE : 0 - 3 GHz
 IMPEDANCE : 50 Ohms

| | | | |
|-----------------|---------|---------|---------|
| FREQUENCY (GHz) | 0 - 1 | 1 - 2 | 2 - 3 |
| V.S.W.R <= | 1.15 | 1.20 | 1.25 |
| INSERT. LOSS <= | 0.15 dB | 0.20 dB | 0.25 dB |
| ISOLATION >= | 85 dB | 80 dB | 75 dB |
| AVER. POWER (*) | 700 W | 500 W | 400 W |

ELECTRICAL CHARACTERISTICS

ACTUATOR : FAILSAFE
 NOMINAL CURRENT AT 25° C (±10%) : 140 mA
 ACTUATOR VOLTAGE (Vcc) : 28V (24 to 30V)
 TERMINALS : D-sub 9 pins

MECHANICAL CHARACTERISTICS

CONNECTORS : N female per MIL C 39012
 LIFE : 2.500.000 cycles
 SWITCHING TIME (nominal voltage;25° C) : < 15 ms
 CONSTRUCTION : splashproof
 WEIGHT : < 215 g

ENVIRONMENTAL CHARACTERISTICS

OPERATING TEMPERATURE RANGE (°C) : -40 , +85
 STORAGE TEMPERATURE RANGE (°C) : -55 , +85

(* : average power at 25° C)

4112-9212 This information is given as an indication. In the continual goal to improve our products, we reserve the right to make any modifications judged necessary

4113-9212 This information is given as an indication. In the continual goal to improve our products, we reserve the right to make any modifications judged necessary

General tolerance: ± 0,5 mm

R577 013005

Page
2/2

DRAWING

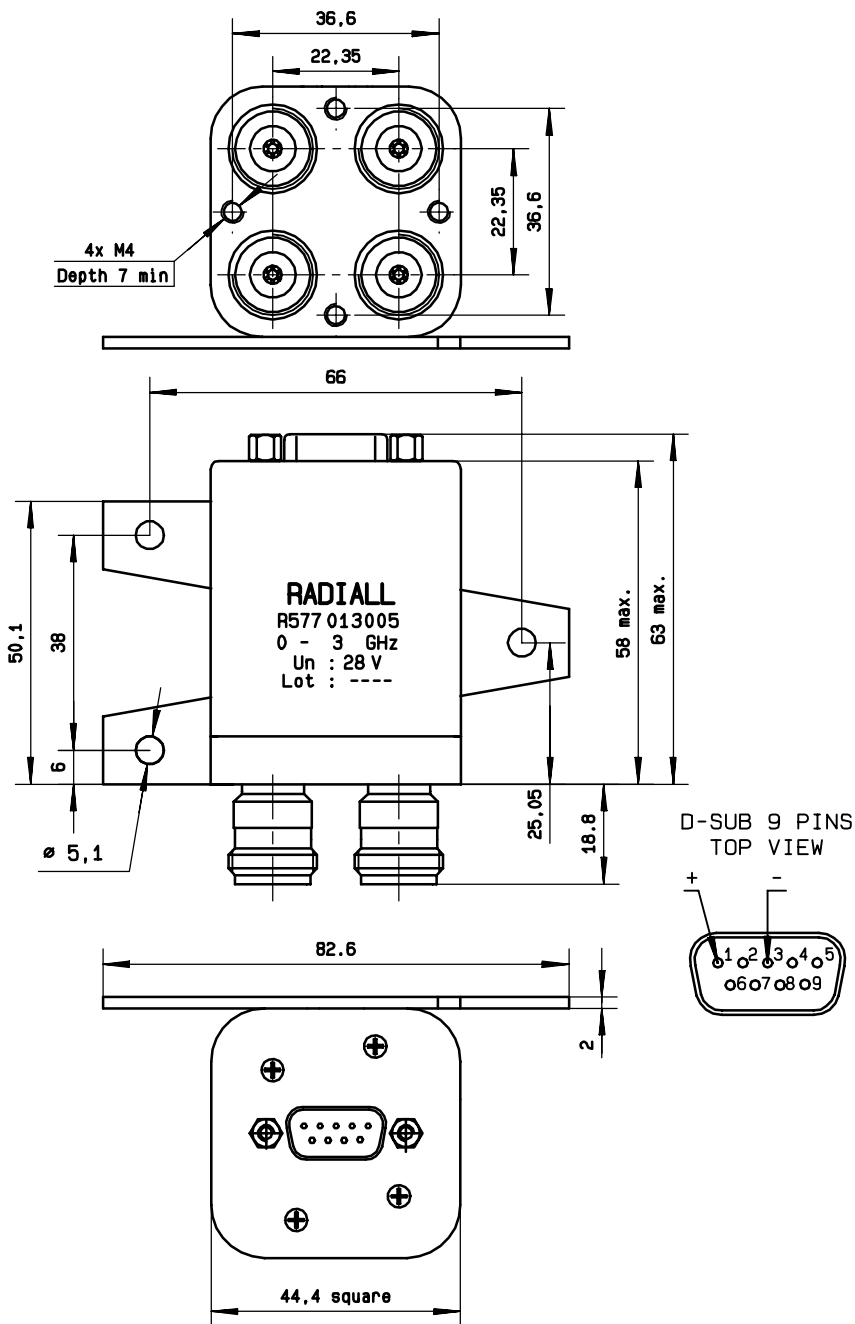
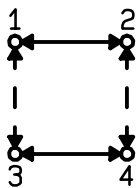

SCHEMATIC DIAGRAM

| | |
|-------------------|---------------------------|
| Voltage energized | RF continuity 1 ↔ 3 2 ↔ 4 |
| De-energized | 1 ↔ 2 3 ↔ 4 |

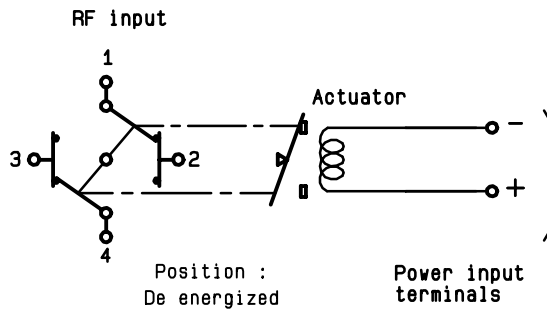

ISSUE 22. jan.08