

Ultra-Wideband Bias Tees

Models K251 and V251

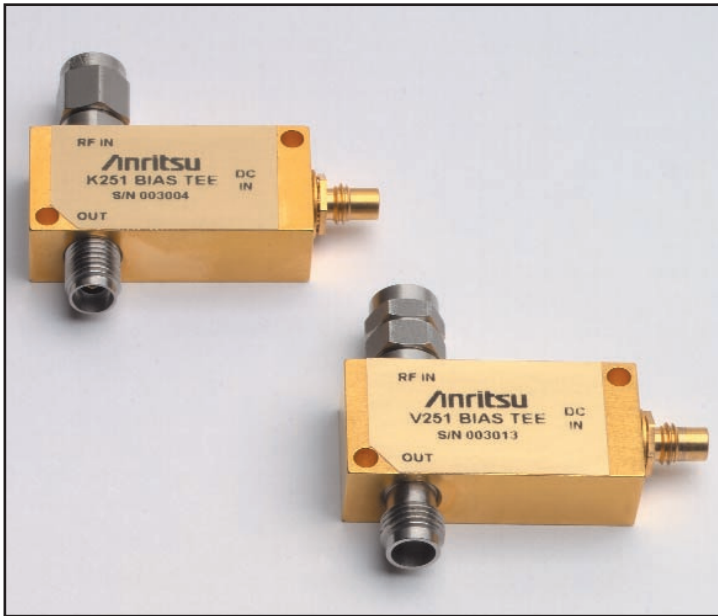

Ideal for Optical Communications Applications

Low Insertion Loss

Risetime: <5 ps (V251)
<7 ps (K251)

Outline Drawings

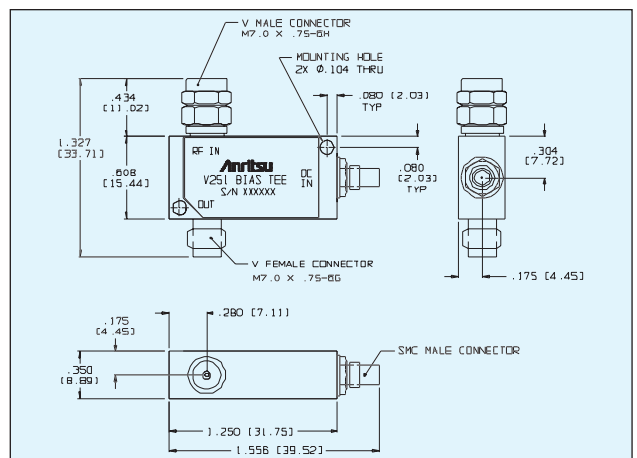
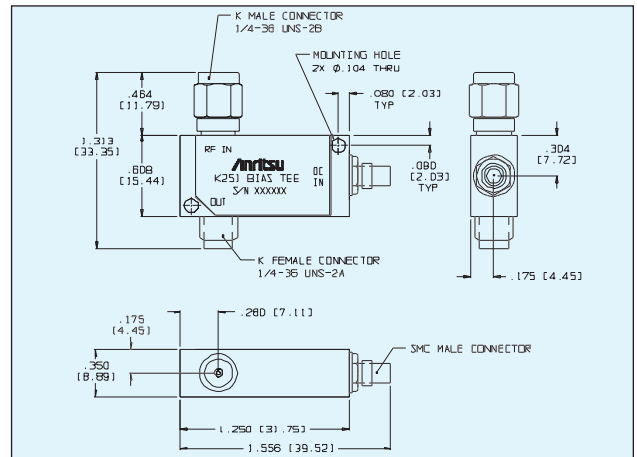

These ultra-wide bandwidth bias tees have been optimized for optical communications and other high-speed pulse, data or microwave applications. Designed to simultaneously apply both DC and RF drive signals to a device via a single input port, these bias tees feature fast rise times, excellent low frequency response, minimum insertion loss and flat group delay. Precision "K"™ and "V"™ connectors assure excellent impedance match across the wide bandwidths available. A one year warranty is provided.

Specifications

Model	K251	V251
Freq. Range: 3dB BW	50 kHz to 40 GHz	100kHz to 65 GHz
Insertion Loss	<2 dB typical	< 2.5 dB typical
Return Loss	See Plot	See Plot
Rise Time	< 7 ps typical	< 5 ps typical
Group Delay	110 +/- 2 ps typical	113 +/-2 ps typical
Max DC Current	100mA	100 mA
Max DC Voltage	16VDC	16VDC
Max RF Power	1 W	1 W
Connectors	RF In: K(m) RF Out: K(f) Bias: SMC(m)	RF In: V(m) RF Out: V(f) Bias: SMC(m)

Specifications apply over the full DC Bias current range and over the temperature range of 0 C to +70 C.

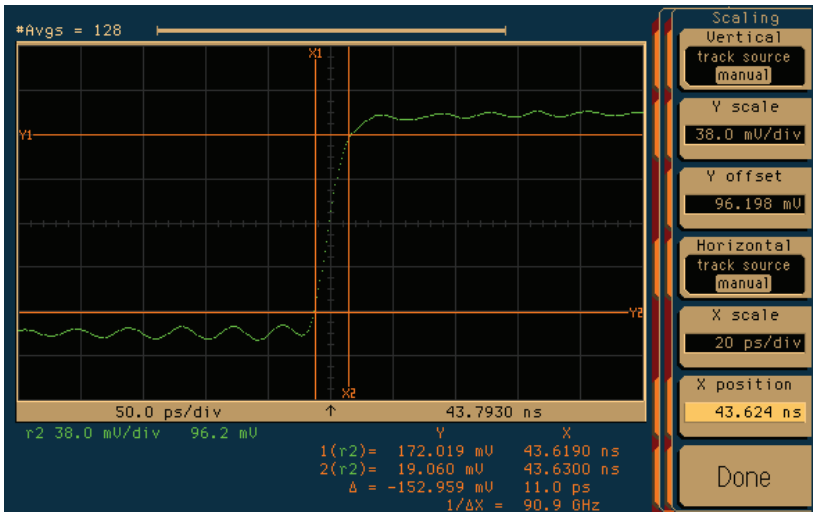
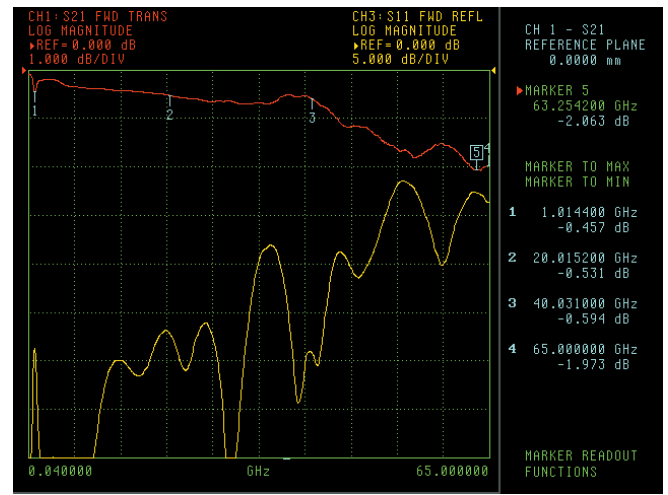
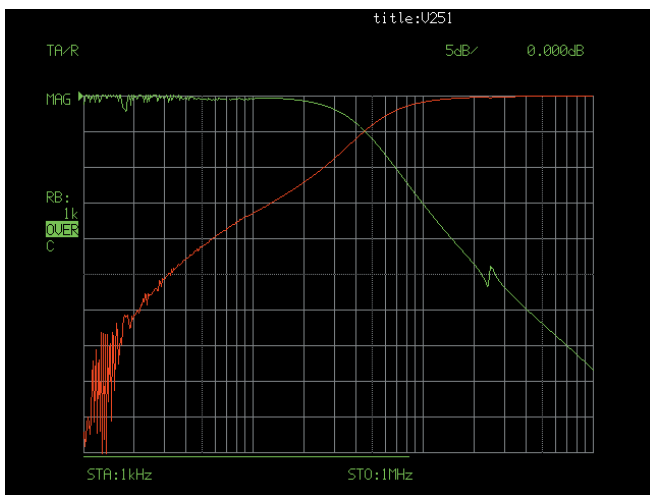
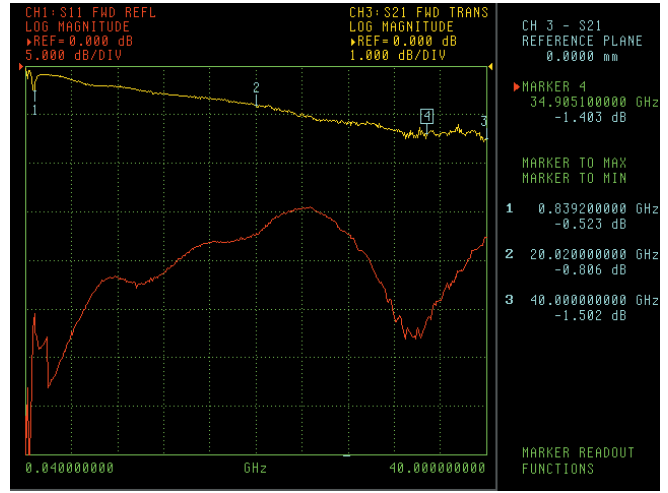
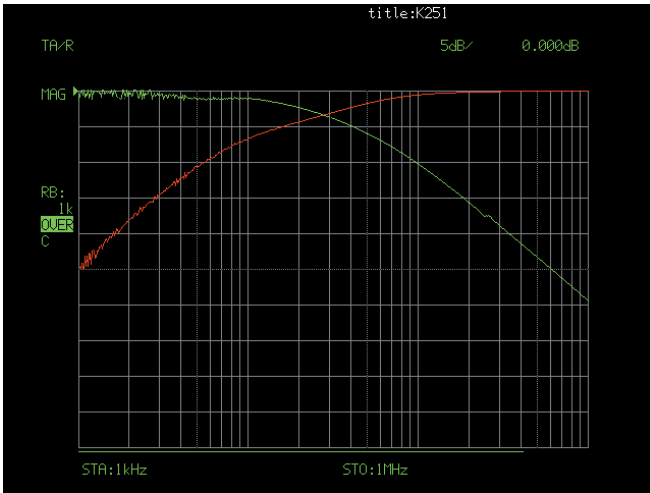

Typical Uncorrected Pulse Response for V251. Absolute risetime for the Bias Tee is derived from this measured data by applying the RSS method to compensate for the risetime of the input pulse.

$$\sqrt{T_{BT}^2 + T_{PG}^2} = T_{meas.}$$

$T_{meas.}$ = uncorrected risetime
 T_{BT} = absolute Bias Tee risetime
 T_{PG} = risetime of input pulse

All trademarks are registered trademarks of their respective companies

Sales Centers:
 US (800) ANRITSU
 Canada (800) ANRITSU
 South America 55 (21) 286-9141

Anritsu

Microwave Measurements Division • 490 Jarvis Drive • Morgan Hill, CA 95037-2809
<http://www.us.anritsu.com> • FAX (408) 778-0239

June 2000; Rev: A
 Data subject to change without notice



Certificate No. 6495

Sales Centers:
 Europe 44 (01582) 433200
 Japan 81 (03) 3446-1111
 Asia-Pacific 65-2822400

11410-00253
 Ultra-Wideband Bias Tees