

R591 RADIALL coaxial subminiature switches have a typical operating life exceeding 25 million cycles. Excellent RF & repeatability characteristics along with a guaranteed life of 10 million cycles make these switches ideal for Automated Test Equipment (ATE) and other measurement applications. These miniature switches are also an excellent choice for Mil/Aero applications due to their small size, light weight, as well as outstanding shock and vibration handling capabilities.

PART NUMBER SELECTION

R 591

Updated revision

RF connectors :
 3 : SMA up to 6 GHz
 7 : SMA up to 26.5 GHz
 E : QMA up to 6 GHz (4)

Type :
 0 : Normally open
 2 : Latching, global reset
 6 : Latching, separated reset (1)

Actuator voltage :
 2 : 12 Vdc
 3 : 28 Vdc

Actuator Terminal :
 0 : Solder pins
 5 : Micro-D connector

Options :
 0 : Without option
 1 : Positive common
 2 : Normally open with TTL driver (high level) (2)&(3)
 3 : With suppression diodes
 4 : With suppression diodes and positive common

Number of positions :
 4 : 4 positions
 6 : 6 positions

(1) : Available with "solder pins" models only
 (2) : Polarity is not relevant to application for switches with TTL driver
 (3) : Suppression diodes are already included with TTL option

PICTURE



Note (4)

The "QLF" trademark (quick lock formula®) standard applies to QMA and QN series and guarantees the full intermateability between suppliers using this trademark. Using QLF certified connectors also guarantees the specified level of RF performances.

In the continual goal to improve our products, we reserve the right to make any modification judged necessary.

GENERAL SPECIFICATIONS

Operating mode		Normally open		Latching	
Nominal operating voltage (across operating temperature)	Vdc	12 (10.2 / 13)	28 (21 / 30)	12 (10.2 / 13)	28 (21 / 30)
Coil resistance (+/-10%)	Ohms	48	250	60	285
Operating current at 23°C	mA	250	110	200	98
Average power		See Power Rating Chart on general catalog			
TTL input	High Level	2.2 to 5.5 Volts			
	Low Level	0 to 0.8 Volts			
Switching time (max)	ms	10			
Life		10 million cycles			
Connectors		SMA / QMA			
Actuator terminals		Solder Pins : double row connector for wrapping, soldering (250°C max / 30 sec), or connecting to 2.54 mm pitch female connector. 9 pin micro-D receptacle M83513/07-A according to MIL-C-85513.			
Operating temperature range	°C	-40 to +85			
Storage temperature range	°C	-55 to +85			
Sine vibration (According to MIL STD 202, Method 204D, Cond. D)		10-2000 Hz, 20g	operating		
Random vibration (According to MIL STD 202, Method 214A, Profile I, Cond. F)		50-2000 Hz, 20.71grms	operating		
Shock (According to MIL STD 202, Method 213B, Cond. C)		100g / 6 ms, ½ sine	operating		

RF PERFORMANCES

Connectors	Frequency Range GHz	V.S.W.R. (max)	Insertion Loss (max) dB	Isolation (min) dB	Impedance Ohms	
QMA / SMA	DC - 6	DC - 3	1.20	0.20	80	50
		3 - 6	1.30	0.30	70	
SMA	DC - 26.5	DC - 3	1.20	0.20	80	50
		3 - 8	1.30	0.30	70	
		8 - 12.4	1.40	0.40	60	
		12.4 - 18	1.50	0.50	60	
		18 - 26.5	1.60	0.60	55	

In the continual goal to improve our products, we reserve the right to make any modification judged necessary.

TYPICAL RF PERFORMANCES

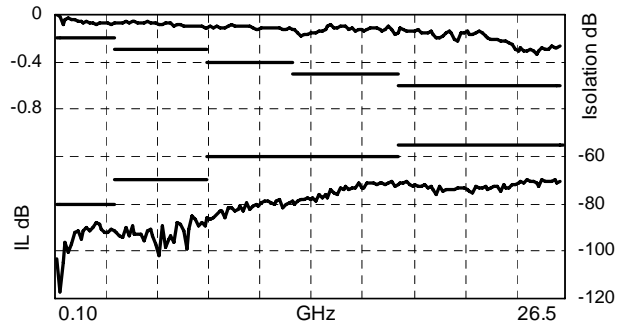

Insertion loss and Isolation

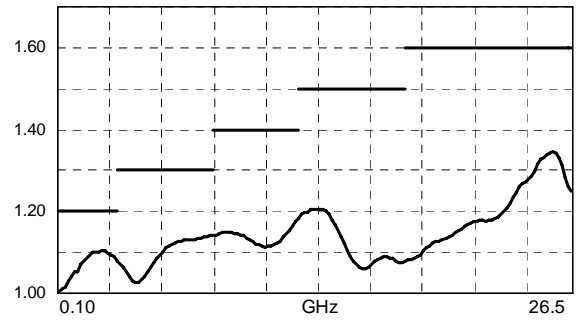

V.S.W.R.

TYPICAL OUTLINE DRAWING (1)

Connectors	SMA	QMA
A max (mm/ inches)	7.4/ 0.291	10.8/ 0.425

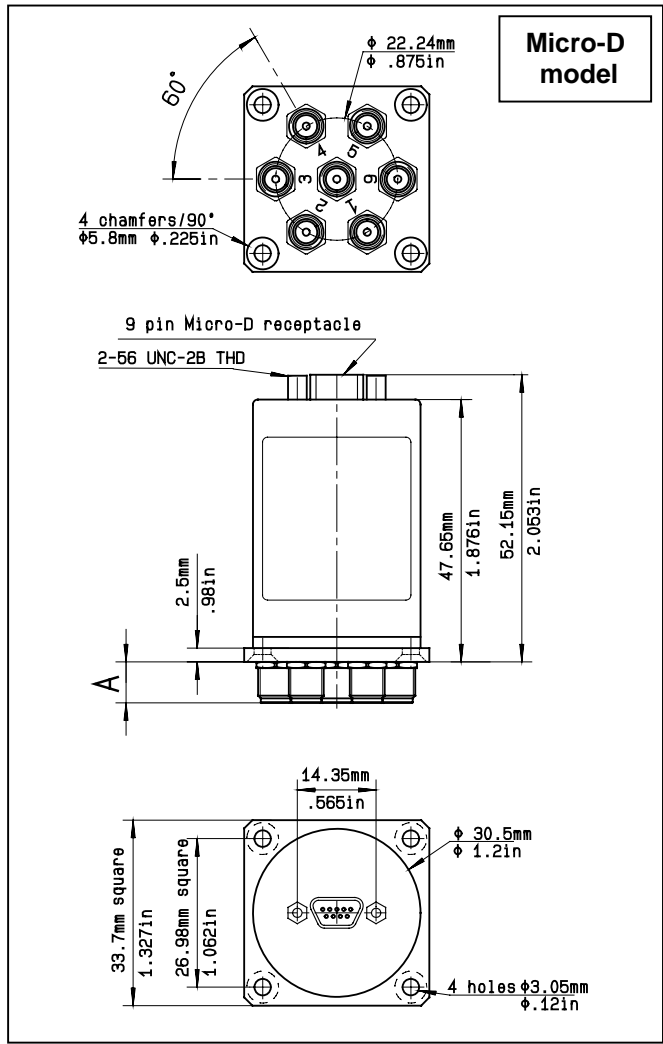
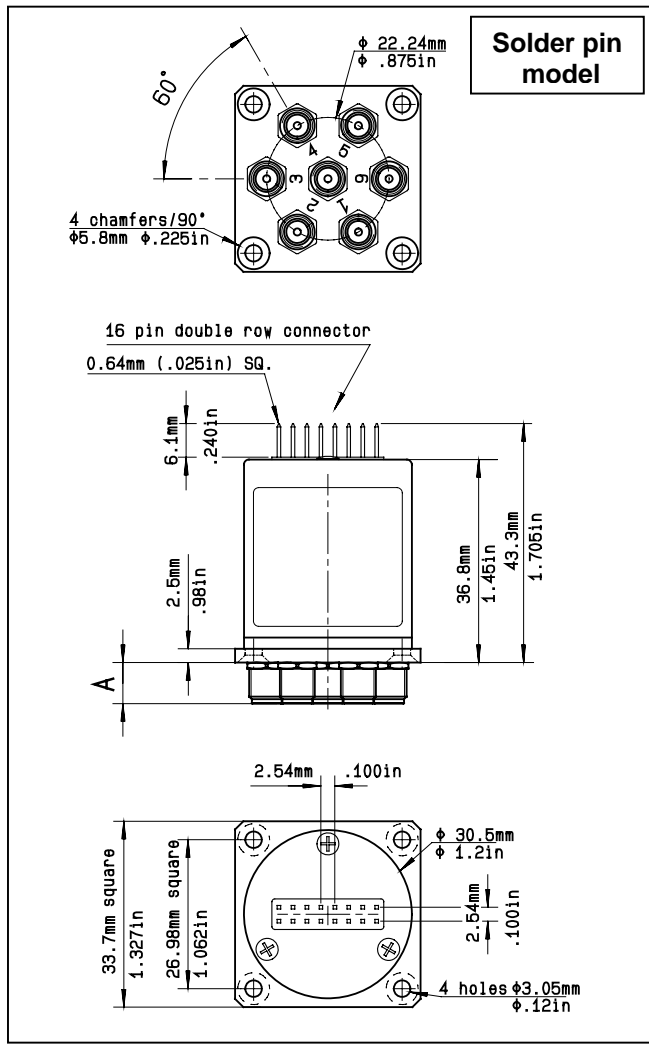

(1) : For SP4T, ways 3 and 6 not connected

all dimensions are in mm/ inches

In the continual goal to improve our products, we reserve the right to make any modification judged necessary.

R591 series electrical schematics

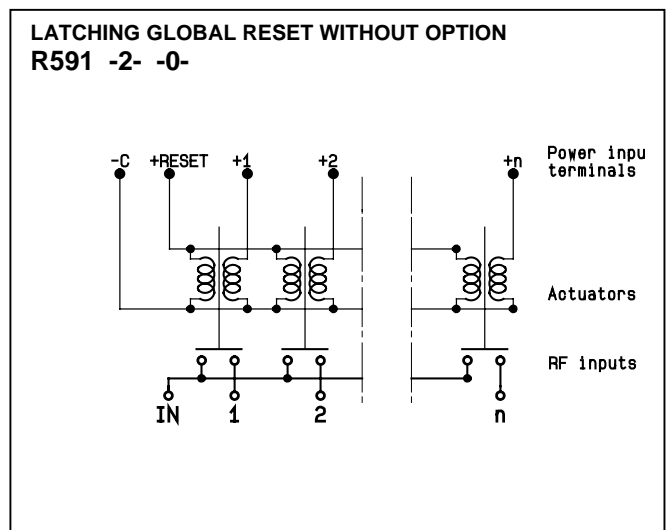
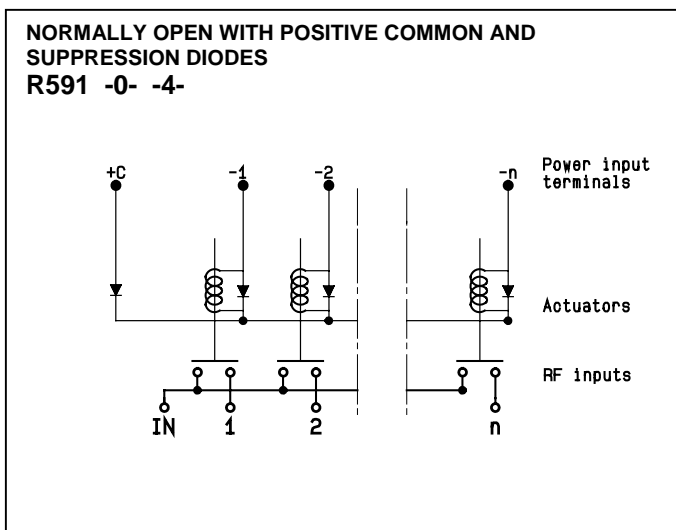
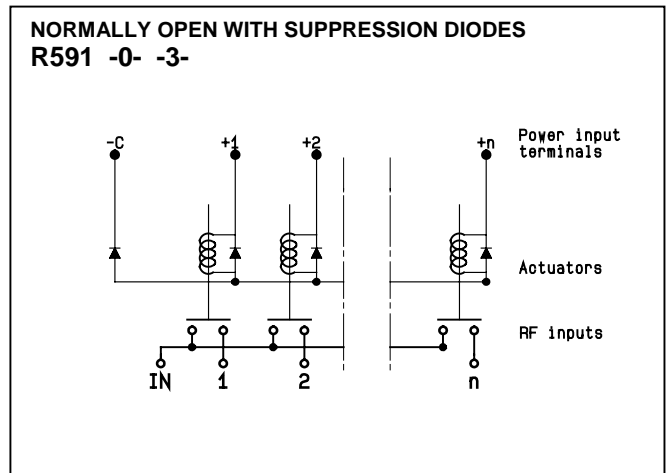
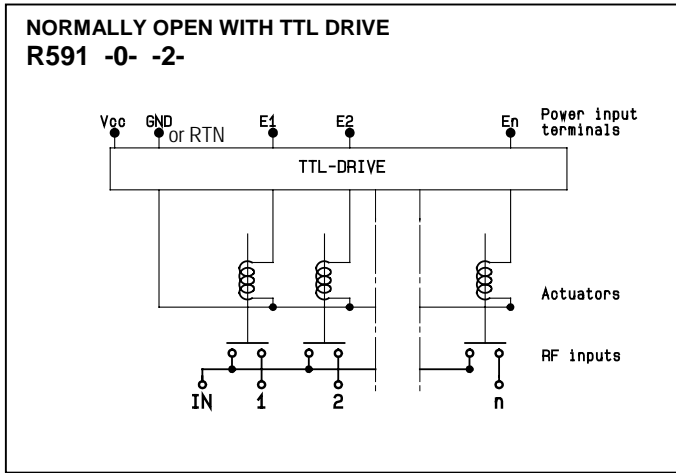
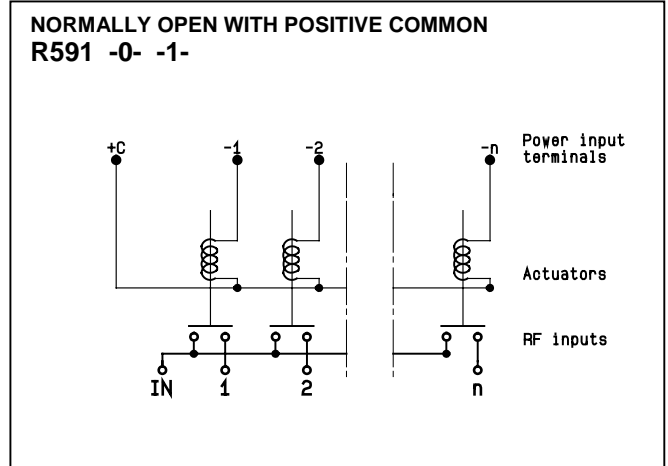
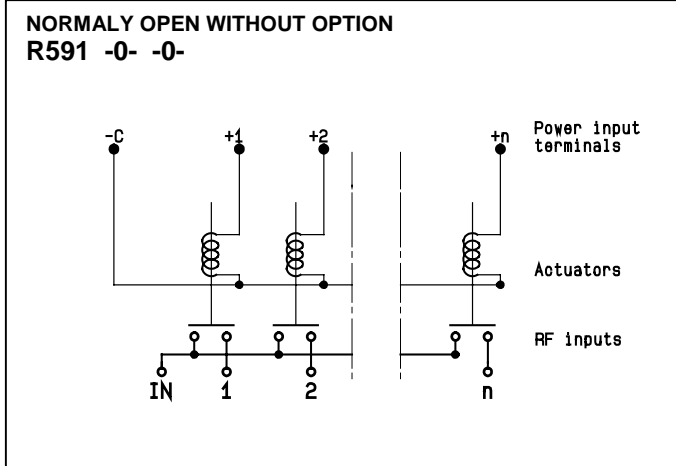

In the continual goal to improve our products, we reserve the right to make any modification judged necessary.

R591 series electrical schematics

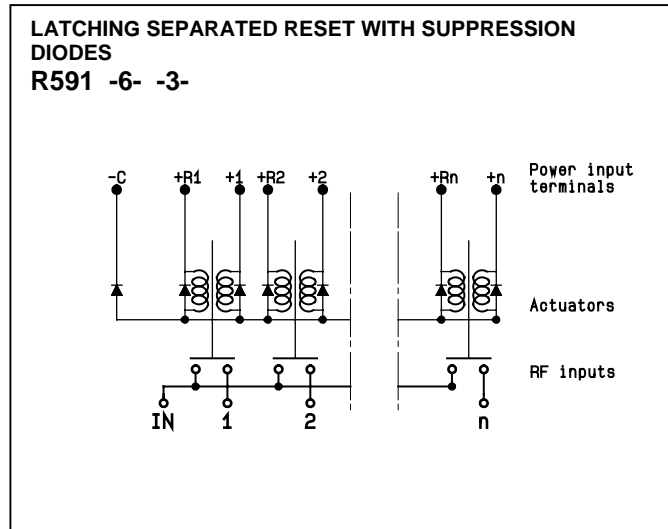
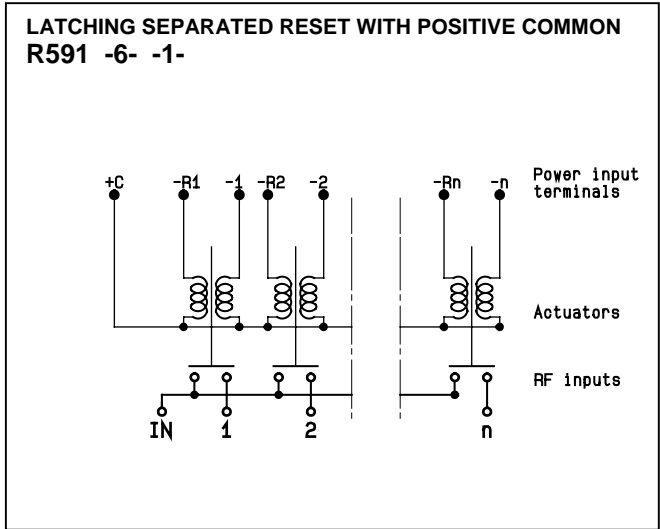
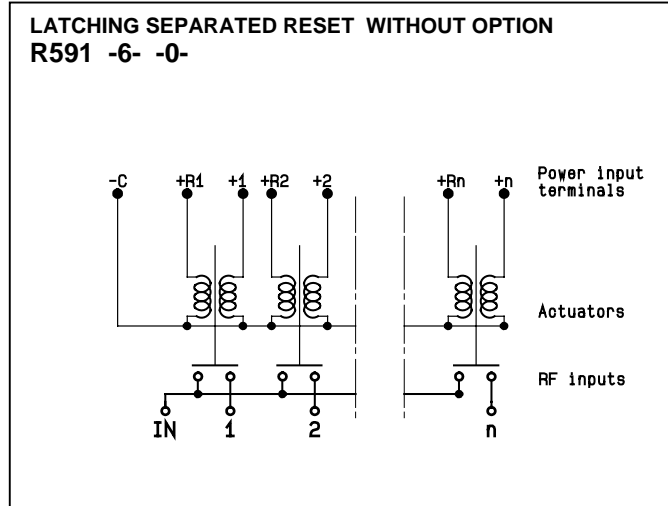
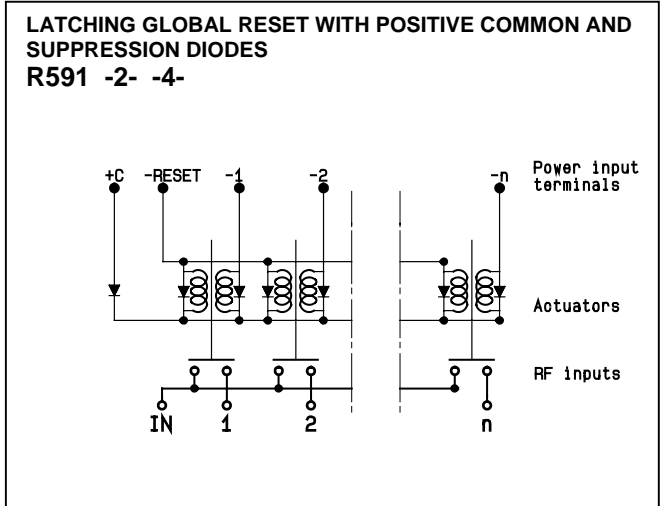
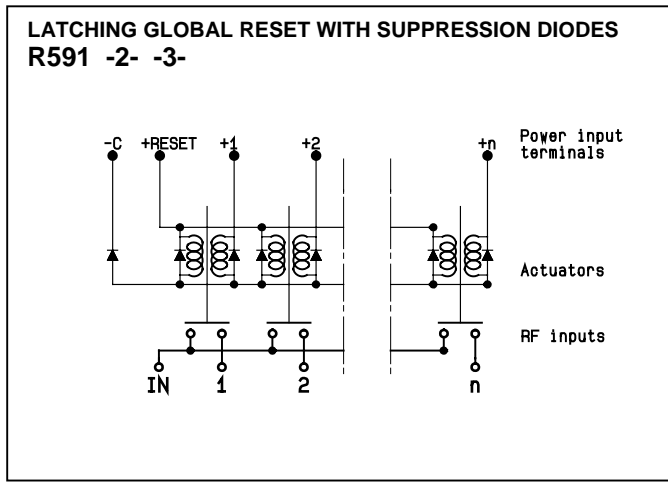
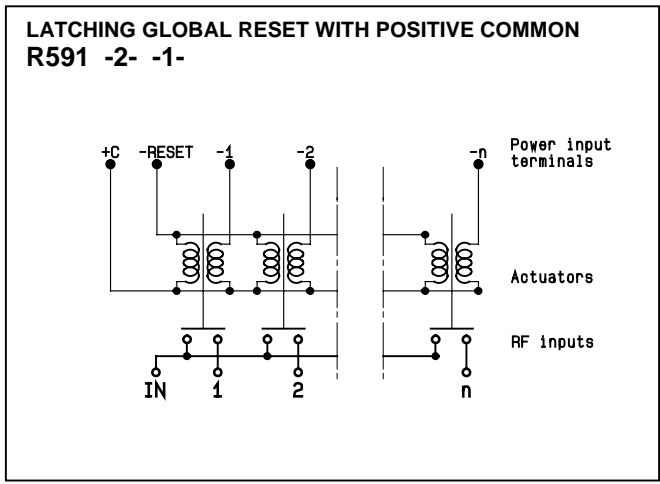

In the continual goal to improve our products, we reserve the right to make any modification judged necessary.

R591 series electrical schematics

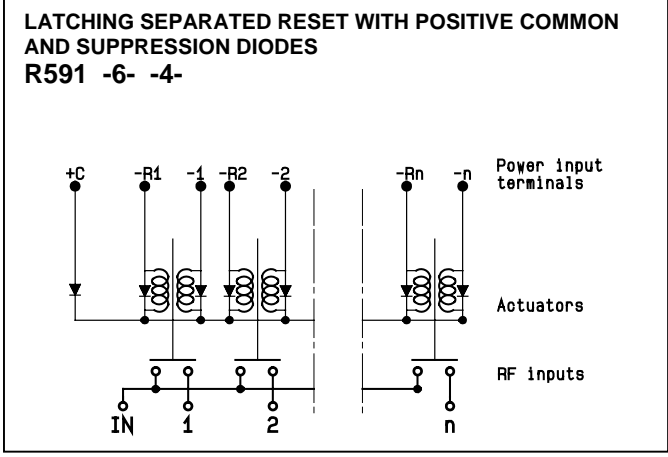

Pin identification

Solder pins (top view)*

9 pin Micro-D (top view)

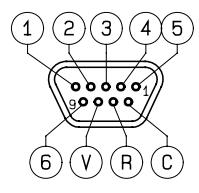
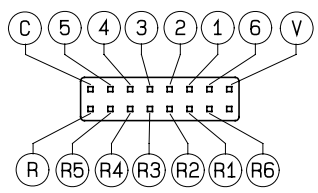

- NC : not connected
- For SP4T, ways 3 and 6 not connected
- Pin R = reset of all paths

* : compatible with 2.54 mm pitch double row 16 contact femelle connector

Type		PIN														
		C	V	1	2	3	4	5	6	R	R1	R2	R3	R4	R5	R6
Normally open	negative common	-C	NC	+1	+2	+3	+4	+5	+6	NC	NC	NC	NC	NC	NC	NC
	positive common	+C	NC	-1	-2	-3	-4	-5	-6	NC	NC	NC	NC	NC	NC	NC
Latching	negative common	-C	NC	+1	+2	+3	+4	+5	+6	+reset	NC	NC	NC	NC	NC	NC
global reset	positive common	+C	NC	-1	-2	-3	-4	-5	-6	-reset	NC	NC	NC	NC	NC	NC
Latching	negative common	-C	NC	+1	+2	+3	+4	+5	+6	NC	+res.1	+res.2	+res.3	+res.4	+res.5	+res.6
individual reset	positive common	+C	NC	-1	-2	-3	-4	-5	-6	NC	-res.1	-res.2	-res.3	-res.4	-res.5	-res.6
Normally open with TTL drive		Gnd or RTN	Vcc	E1	E2	E3	E4	E5	E6	NC	NC	NC	NC	NC	NC	NC

In the continual goal to improve our products, we reserve the right to make any modification judged necessary.